

CP-4545-FP-CP9

45x45 (Square) Plastic Chemical Pallet



Technical Data

Dimensions 44.9x44.9x5.9 inches (1140x1140x150 mm)
Weight 28.5 lbs

Load Capacities

Static 6200 lbs
Dynamic 3100 lbs
Racking --

Entry 4-way
Truckload Qty 416
Stack TL / LTL -- / 16

TL (truckload) and LTL (less-than-truckload) quantities are approximate and may vary by transport equipment or other factors.

Handling Data

Nestable No	Reusability Multi-Trip	ISPM-15 Exempt Yes
Stackable Yes	Destination Captive & Export	Food Grade Yes, non-FDA
Rackable No	Airfreight Yes	Pharmaceutical Yes



Materials and Colors

Condition
New

Material HDPE/PP (Recycled) **Color** Black

(High-Density Polyethylene/Polypropylene)

Deck Specs

Top Deck
Open

Bottom Deck
6 Runner - Perimeter+2 Cross
(cruciform perimeter base)

Available Options:
12 grommets under deck

Features

Note: CP-4545-FP-CP9 was previously known as NPP-4545-FP-CP9

- Matches dimensions of CP9 chemical pallet w/ hooks on corners for securing stretch wrap
- One-piece design reduces weak points and the potential for cracks
- Wide angle runners allow for easy forklift entry, preventing bag tears and other damage
- Unique top deck reduces the need for slip sheets and dividers
- Allows for safe double stacking
- Easy-to-clean hygienic design
- Suitable for packaged food items *(not approved for direct food contact)*
- Sanitary choice for many pharmaceutical applications
- Impervious to acids, fats, solvents and odors
- Resists water absorption & bacteria growth
- Inert to infestation, mold and mildew
- Consistently dimensionally accurate
- Exempt from ISPM 15 shipping regulations

NelsonTM

The Nelson Company
(443) 649-5294

plastic@NelsonCompany.com

www.NelsonCompany.com

www.NelsonTechCenter.com

CP-4545-FP-CP9

45x45 (Square)
Plastic Chemical Pallet



Technical Drawings

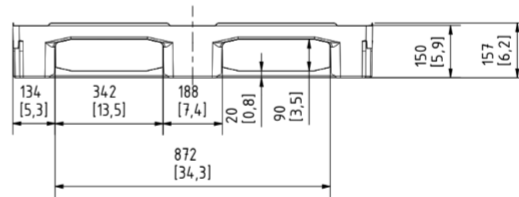
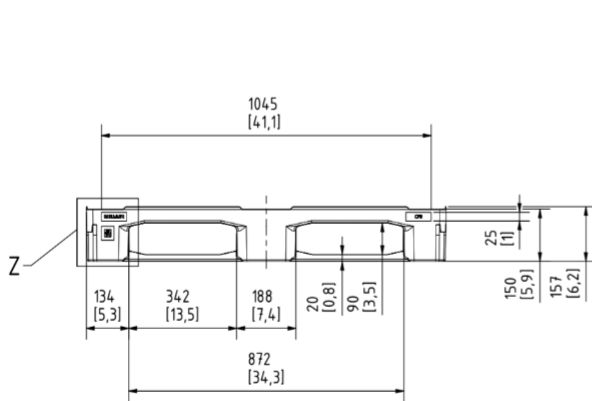
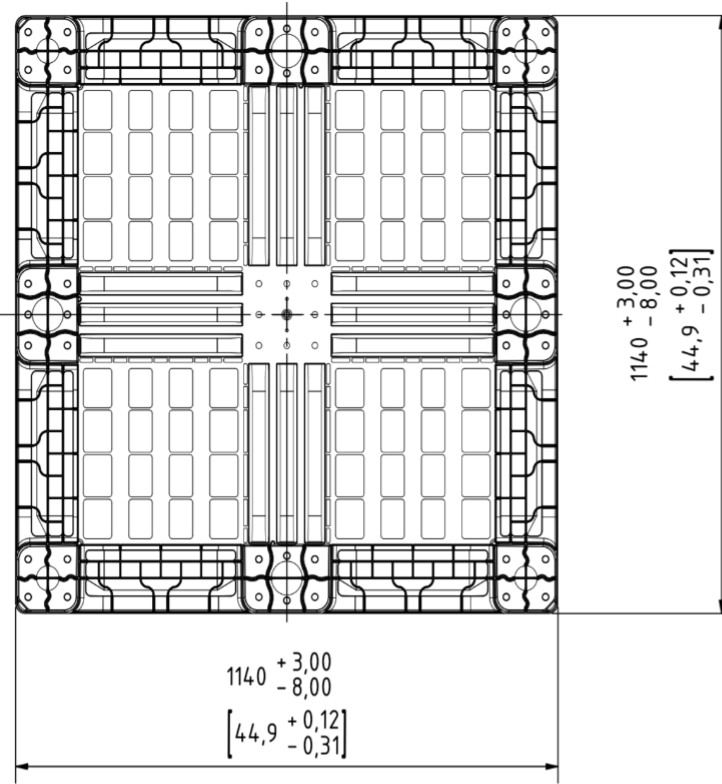

NelsonTM

The Nelson Company
(443) 649-5294

plastic@NelsonCompany.com

www.NelsonCompany.com

www.NelsonTechCenter.com