

CP-4840-FP-E6CD-FDA

48x40 (Standard) Plastic Industrial Pallet



Technical Data

Dimensions 48x40x6.1 inches (1219x1016x155 mm)
Weight 40.0 lbs

Load Capacities

Static 8800 lbs
Dynamic 4400 lbs
Racking 2200 lbs

Entry 4-way
Truckload Qty 510
Stack TL / LTL 17 / 15

TL (truckload) and LTL (less-than-truckload) quantities are approximate and may vary by transport equipment or other factors.

Handling Data

Nestable No	Reusability Multi-Trip	ISPM-15 Exempt Yes
Stackable Yes	Destination Captive	Food Grade FDA Blue
Rackable Yes	Airfreight Yes	Pharmaceutical Yes

Materials and Colors

Condition
New

Material HDPP
Color Blue

(High-Density Polypropylene)

It is the sole responsibility of end-user to conduct a thorough risk assessment to ensure the pallet material and design are compatible with internal sanitation protocols and specific regulatory requirements.

Deck Specs

Top Deck
Closed

Bottom Deck
6 Runner - Perimeter+2 Cross
(cruciform perimeter base)

Available Options:
RFID Transponders
Individual Markings
Anti-Slip Bottom Grommets
ESD Prevention for Anti-Static
Rod Inserts for Increased Performance.

Features

Note: CP-4840-FP-E6CD-FDA was previously known as NPP-4840-FP-E6CD-FDA

Ideal for closed loops or distribution chains across industry sectors including Food, Retail, Medical and Pharmaceutical.

- Classic FDA blue color helps distinguish pallets in your system
- Virgin material may be available for direct contact applications (ask for details)
- High performance at low cost
- Top Safety Rim
- Allows for safe double stacking
- Impervious to acids, fats, solvents and odors
- Resists water absorption & bacteria growth
- Inert to infestation, mold and mildew
- Consistently dimensionally accurate
- Exempt from ISPM 15 shipping regulations

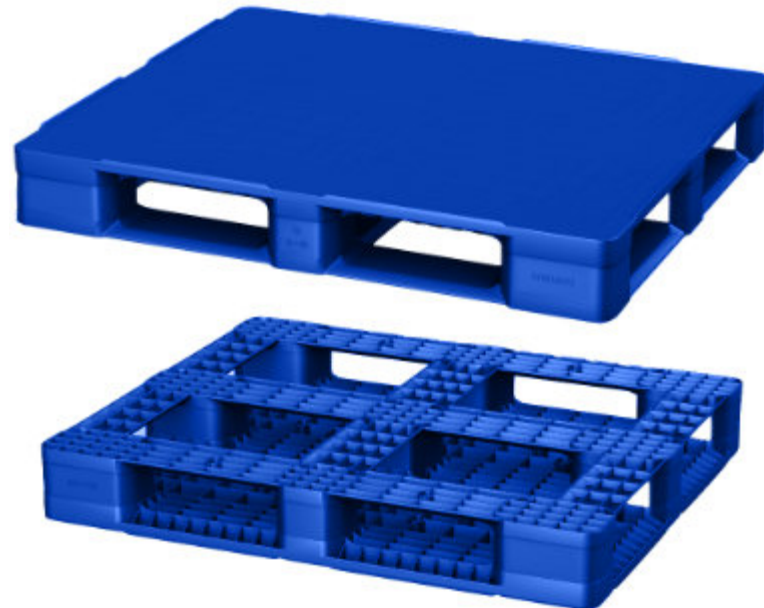

NelsonTM

The Nelson Company
(443) 649-5294

plastic@NelsonCompany.com
www.NelsonCompany.com
www.NelsonTechCenter.com

CP-4840-FP-E6CD-FDA

48x40 (Standard)
Plastic Industrial Pallet



Technical Drawings

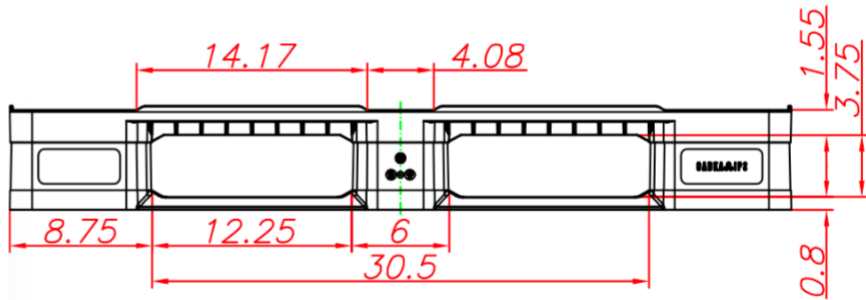
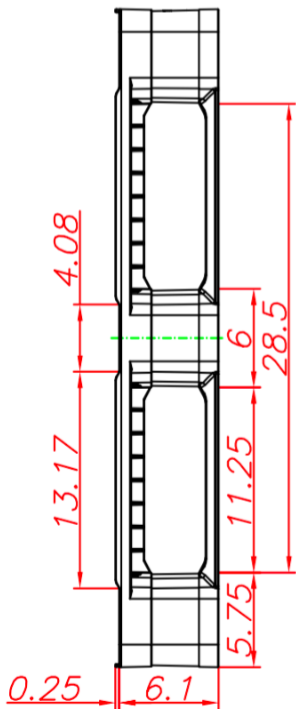
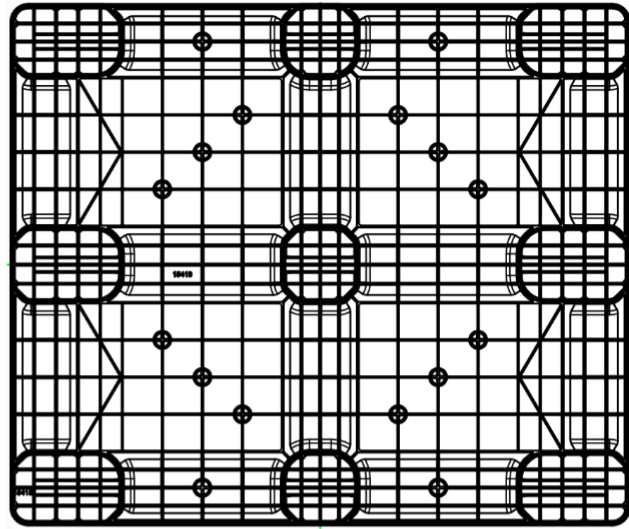
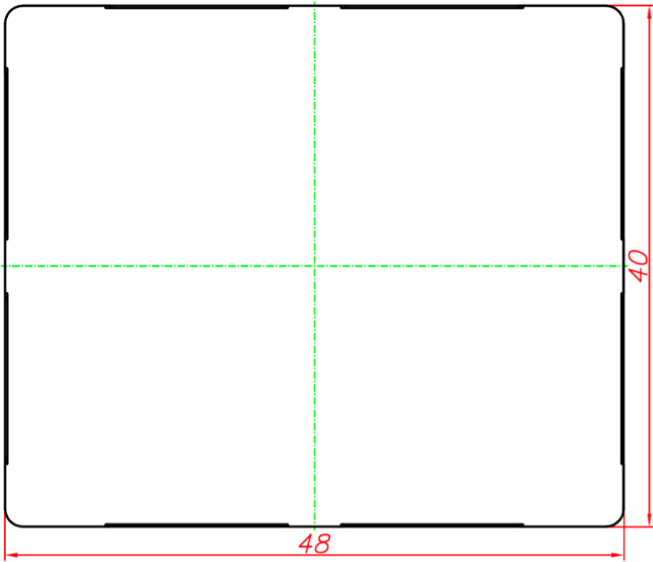

NelsonTM

The Nelson Company
(443) 649-5294

plastic@NelsonCompany.com

www.NelsonCompany.com

www.NelsonTechCenter.com